

# Crab Cavity Operation in a Hadron Ring

Jean Delayen (Lead PI), Subashini De Silva (ODU)

Qiong Wu (Co-PI), Silvia Verdú-Andrés (BNL)

Geoffrey Krafft (Co-PI), HyeKyoung Park, Vasiliy Morozov (JLAB)

# Project Description

- Crab cavities are necessary and were prioritized by the Electron Ion Collider Advisory Committee for Electron-Ion Colliders (EIC), and essential for all high luminosity colliders.
- Use of crab cavities in EIC carry some risk, and the 2017 Report of the Community Review of EIC R&D for the Office of Nuclear Physics identified “Crab cavity operation in a hadron ring” as the **top R&D priority**. This proposal addresses directly that recommendation.

Row No.	Proponent	Concept / Proponent Identifier	Title of R&D Element	Panel Priority	Panel Sub-Priority
1	PANEL	ALL	Crab cavity operation in a hadron ring	High	A

- Scientists in our collaboration have been major contributors to the development of crabbing systems in the preceding LARP and on-going LHC HiLumi programs.
- By participating in the crab cavity project for the high luminosity upgrade of the Large Hadron Collider, especially the machine development experiments, we will have this non-repeatable opportunity for preliminary studies of the beam-cavity interaction.
- Output information from this proposal, such as limitations from the crab cavity design will become useful input to the beam dynamics study for crab crossing scheme, such as partial tasks described in the proposal of ‘Development and test of simulation tools for EIC beam-beam interaction’.
- **With the EIC cite decision the work carried out in this proposal is now focused in applying the experience to EIC crab cavities.**
- **Recent EIC Reviews have confirmed that crab cavity systems are critical for EIC – DOE OPA Review (Sep. 2020) and DOE Conceptual Design Review (Nov. 2020).**

# Budget Summary

	FY18 + FY19 + FY20 (k\$) *	Total (k\$)
Funds Allocated	708 + 220	928
Actual Cost	419 + 122	541

\* Red BNL and TJNAF Base  
Black Funding directed to ODU

# Deliverables and Schedule

	FY18 Q4	FY19 Q1	FY19 Q2	FY19 Q3	FY19 Q4	FY20 Q1	FY20 Q2	FY20 Q3	FY20 Q4	FY21 Q1	FY21 Q2	FY21 Q3	FY21 Q4	Status
Analysis of off-line room temperature and cryogenic tests														√
Routine remote communication with CERN														Ongoing
Remote preparation for test														√
Participation in rf beam synchronization														√
Participation in transparency tests														√
Participation in emittance and stability measurements														√
Participation in high-intensity experiments														√
Analysis of test results														Ongoing
Benchmarking simulations with SPS data														Ongoing
Analytical calculation on crab cavity impedance														Ongoing
Computer simulation on crab cavity impedance														Ongoing

<b>Performed by:</b>	<b>Full Collaboration</b>	<b>ODU/JLAB</b>	<b>BNL</b>
----------------------	---------------------------	-----------------	------------

# Some Project Specifics

- Crab cavities for LHC, design and experiments
- Cryomodule development for SPS test
  - DQW cryomodule → Future plans
  - RFD cryomodule → Current status
- Beam dynamics study
- Benefits to EIC crab cavity
- Documentation
- Future plan
- Summary

# Crab Cavities for LHC

- Crab cavity for LHC program started in the US LHC Accelerator R&D Program (US LARP) in 2008 and continued in the US HL-LHC Accelerator Upgrade Project (AUP) into production mode.
- LARP program fostered two successful designs of crab cavities to the Hi-Lumi LHC program to recover a luminosity loss of 70% or more due to the crossing angle at the interaction region.
- Hi-Lumi LHC requires a 400 MHz crab cavity to deliver a total of 10 MV per beam per side.
- Crabbing in both vertical and horizontal directions are required by different physics experiment sites.
- EIC design requires 197 and 394 MHz crab cavities in horizontal crabbing.
- EIC designs can benefit from the LHC crab cavity designs and the lessons learned from their performance in the tests conducted in the SPS at CERN.

# Two Crab Cavity Designs Delivered by LARP

Double Quarter Wave (DQW)



$f_0 = 400 \text{ MHz}$   
 $V_T = 3.4 \text{ MV/cavity}$   
( $E_p, B_p < 40 \text{ MV/m}, 70 \text{ mT}$ )  
Beam aperture = 84 mm  
Beam-to-beam dist = 194 mm  
Common FPC = 40 kW-CW  
Operating Temp = 2 K

RF Dipole (RFD)

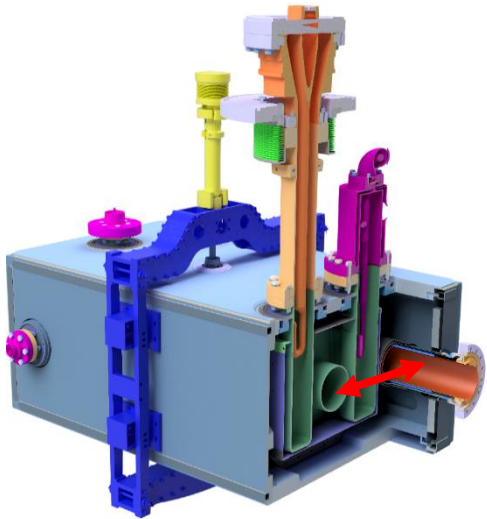
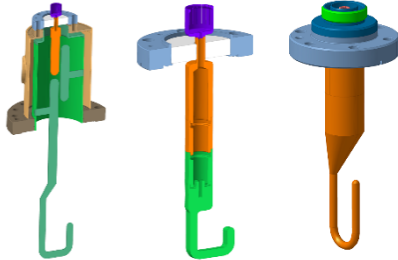
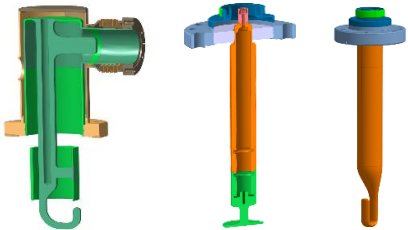
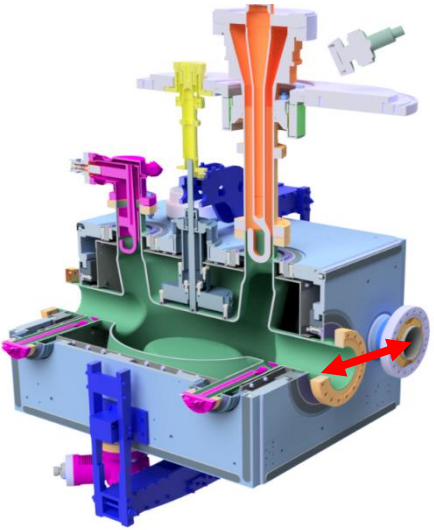
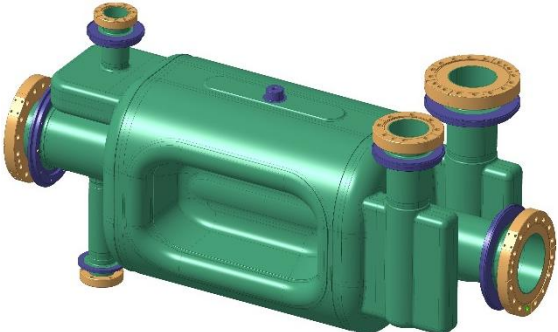

©R. Calaga, 10th HL-LHC Collaboration Meeting, CERN, Oct 5-7, 2020

# Experience of our collaboration in HL-LHC Prior to this FOA

- Delivered DQW and RFD RF design
- Participated in fabrication of all LARP cavities
- Participated in the DQW cavity and HOM coupler production for SPS @ CERN
  - Fabrication
  - Trim tuning
  - Helium vessel and tuner assembly
- Participated in final design and fabrication of DQW and RFD cavities to be installed in the SPS
- Participated in tests
  - More than 30 vertical tests of DQW and RFD cavities and HOM couplers at JLAB
  - DQW cavity with HOM coupler and tuner vertical tests at CERN
  - Cryomodule test in SM18 at CERN
- Improved LHC designs from the lessons learned
- Validated SPS prototype designs, with a goal to demonstrate ultimate SRF performance



# Two Crab Cavities for SPS/LHC

Double Quarter Wave (DQW)



RF Dipole (RFD)

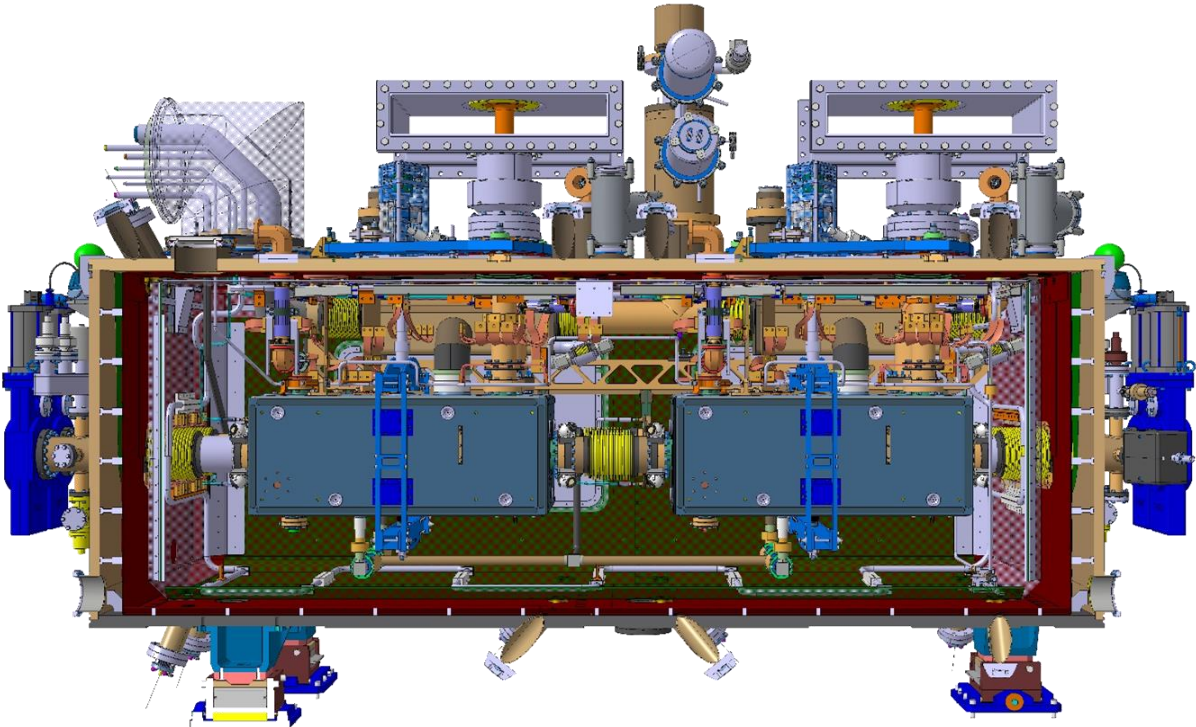
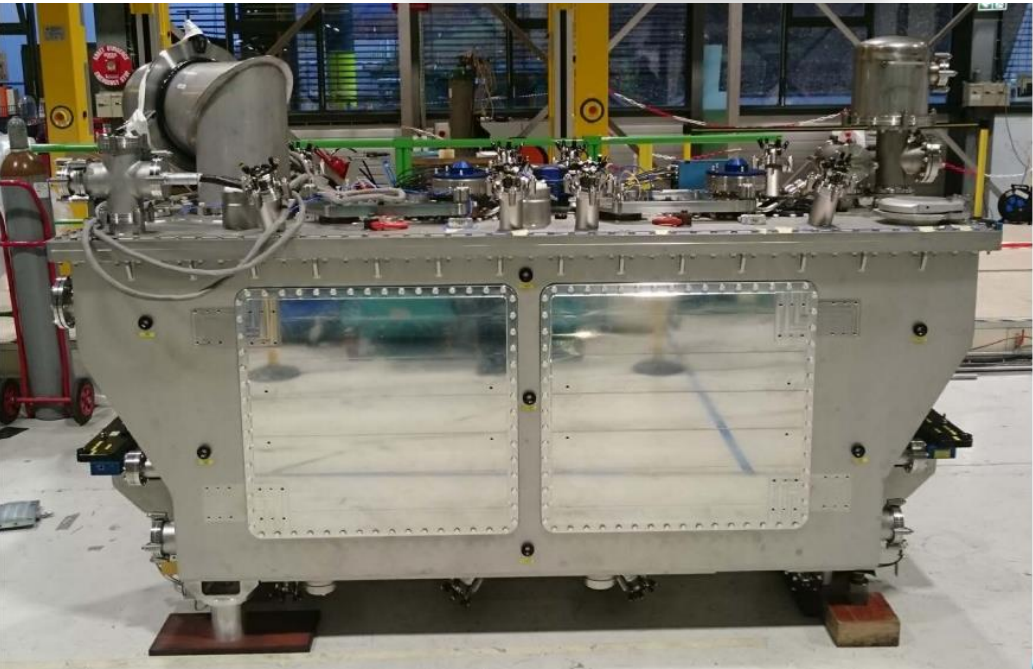

©O. Capatina, 7<sup>th</sup> HL-LHC Collaboration Meeting, CIEMAT, Madrid, Nov 13-16

©R. Calaga, 10<sup>th</sup> HL-LHC Collaboration Meeting, CERN, Oct 5-7, 2020

# DQW Cryomodule in SPS

## First Crabbing of a Hadron Beam

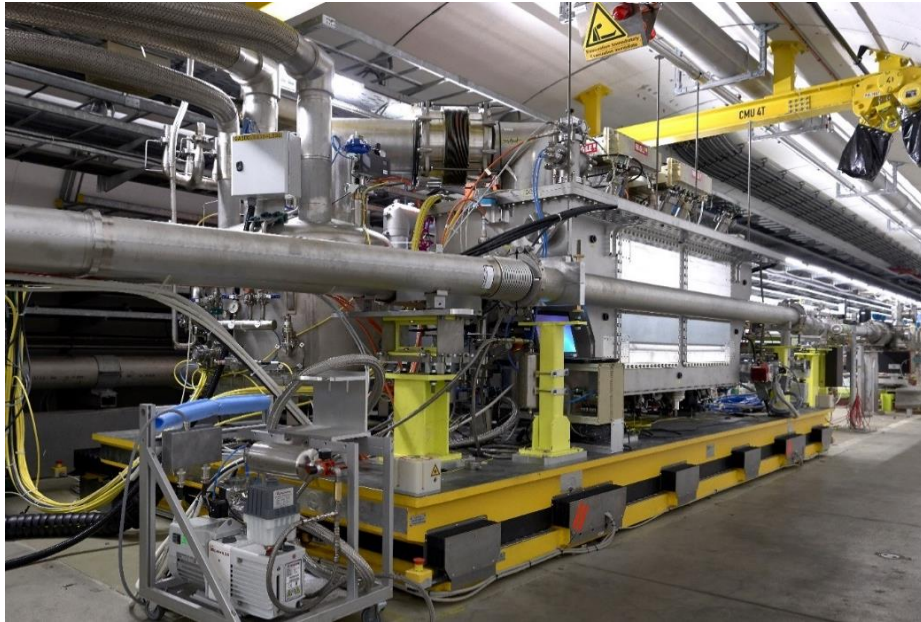

- DQW cryomodule operation on SPS: May-Oct, 2018
- Demonstrated crabbing of the proton beam – May 23, 2018
  - Results are preliminary and still tentative due to the low ( $\sim 1$  MV) crabbing voltage in the cavities
- Module will remain in the SPS for further MDs
  - Further MDs planned for 2011-22
  - For recommissioning, work on cryogenics, tuning system and cabling is completed
- Planned tests are beyond the timescale of the current FOA
  - We are planning to submit a follow-on proposal to participate in planning and executing the next DQW and RFD cryomodule tests

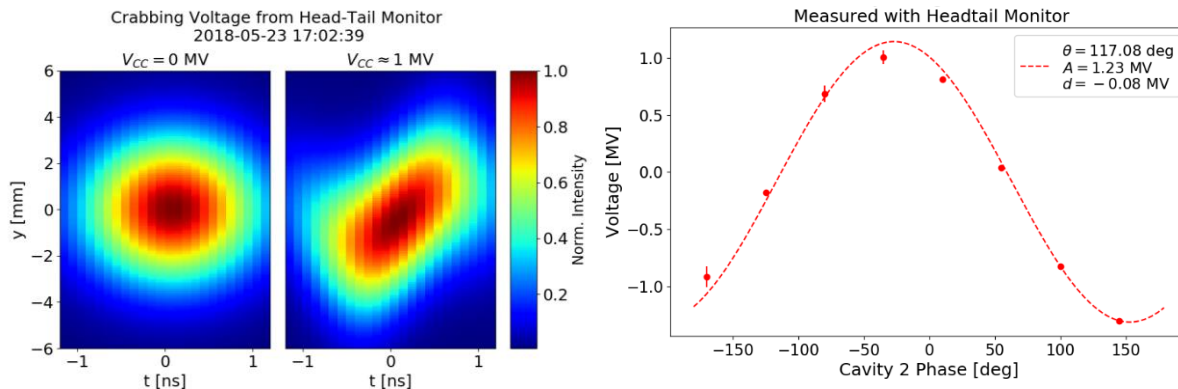

©R. Calaga, 9<sup>th</sup> HL-LHC Collaboration Meeting, Fermilab, Oct 14-16, 2019

# Production of SPS-RFD Cavities at CERN

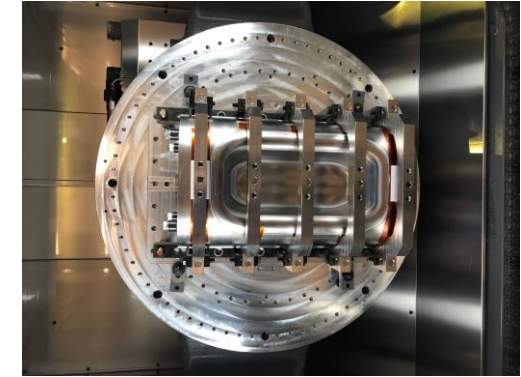
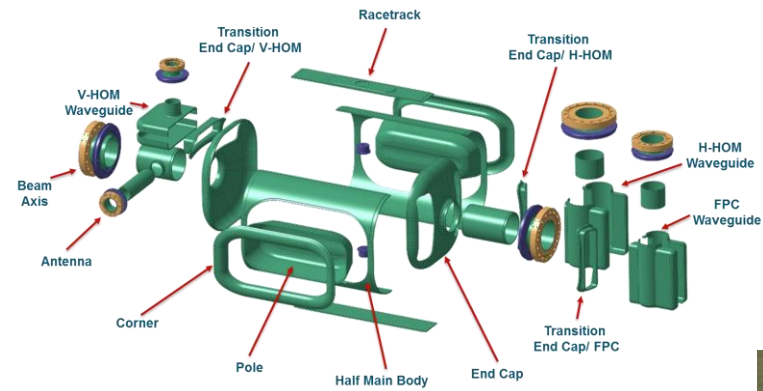

Frequency shift during He-tank assembly  
 $\sim \pm 15$  kHz (negligible)

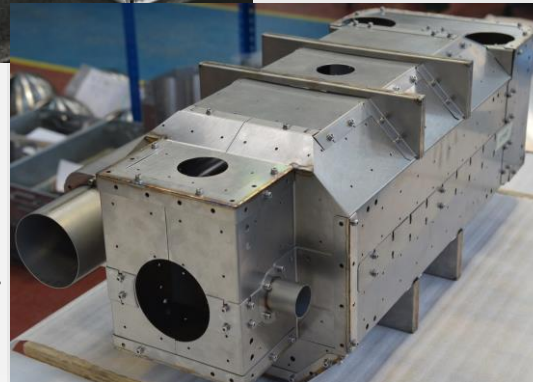

Cold magnetic shields from UK-collaboration



RFD2 Helium tank welded and pressure tested successfully

©O. Capatina, 9<sup>th</sup> HL-LHC Collaboration Meeting, Fermilab, Oct 14-16

©R. Calaga, 10<sup>th</sup> HL-LHC Collaboration Meeting, CERN, Oct 5-7, 2020

# Production of SPS-RFD Cavities at CERN

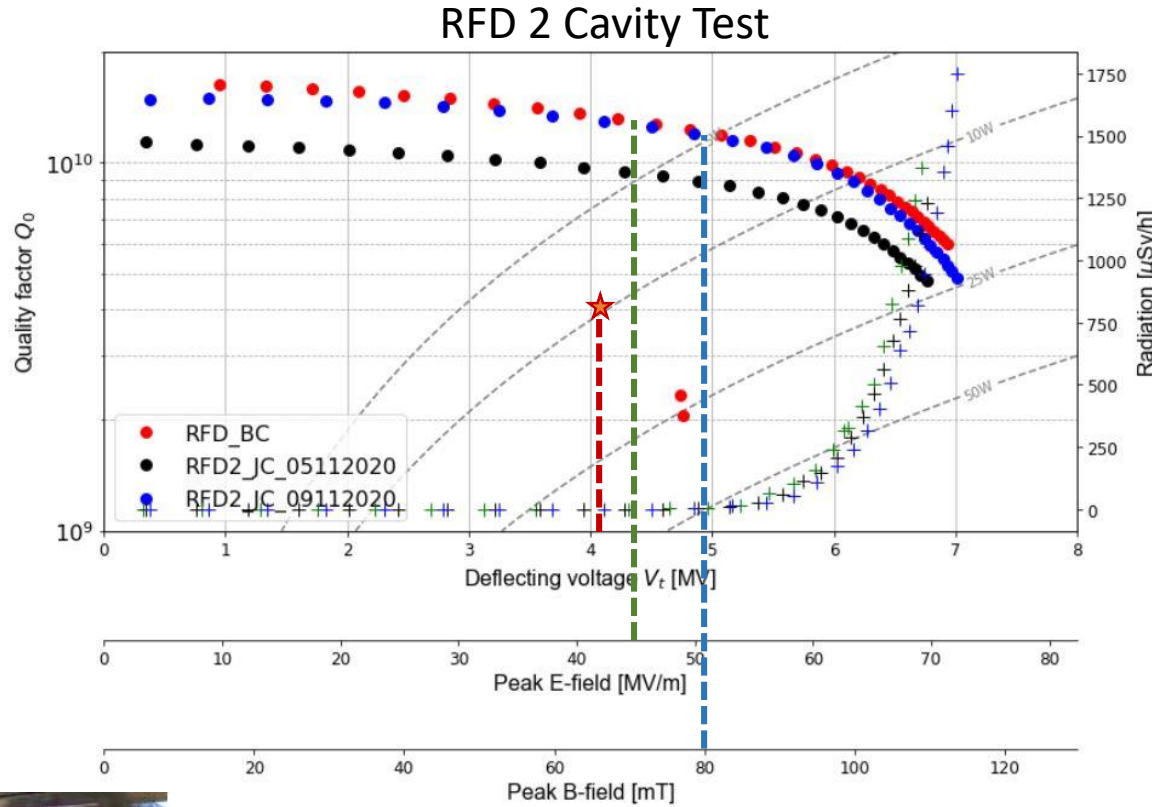

- Cold tests of RFD cavities of the RFD-SPS cryomodule
  - RFD1 – bare cavity test completed
  - RFD2 – bare cavity and jacketed cavity tests completed
- RFD2 achieved remarkable performance in both bare cavity and jacketed cavity tests
  - $V_t > 7$  MV (operational 3.4 MV)
  - $Q_0 > 1 \times 10^{10}$  at operational  $V_t$



Lessons learned applicable to EIC crab cavities:

- Performance of these cavities clearly exceed the design assumptions (45 MV/m and 80 mT) of the EIC cavities
- Cavity trim tuning and processing techniques for production

© HL-LHC WP4-CERN ©R. Calaga, 10<sup>th</sup> HL-LHC Collaboration Meeting, CERN, Oct 5-7, 2020

# SPS Cryomodule Test Plan

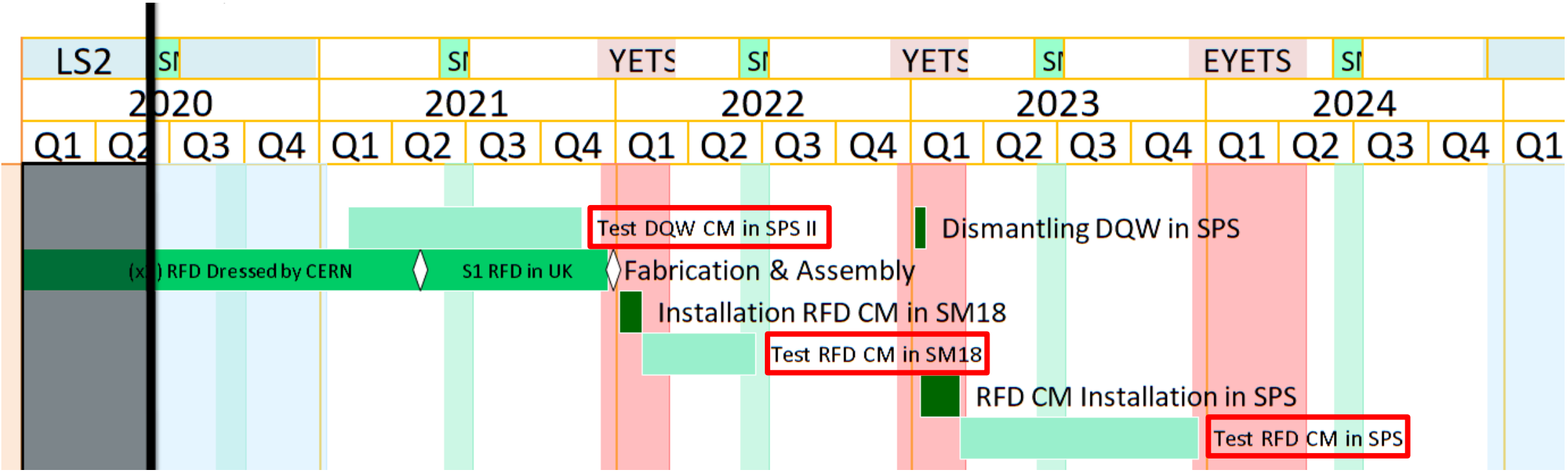

- Expected participation in the cryomodule tests:
  - Contribution in MD planning to learn for EIC
  - 2021 Q1-Q4 → DQW CM Test II in SPS
  - 2022 Q1-Q2 → RFD Test in SM18
  - 2023 Q1-Q4 → RFD Test in SPS

©R. Calaga, 10<sup>th</sup> HL-LHC Collaboration Meeting, CERN, Oct 5-7, 2020

# Benchmarking of Codes against SPS Measurements

- Access to SPS test data through CERNBox
- Data analysis carried out at CERN through Service for Web base ANalysis (SWAN) and Jupyter notebook
- SPS lattice successfully converted to Elegant
  - Know locations of the crab cavities and beam parameters
  - Also have access to logbook and analyzed data
- Studies selected for benchmarking
  - CC phase variation
  - CC transparency test
  - Noise study
  - Beam offset study

Elegant

Semi-analytic code available

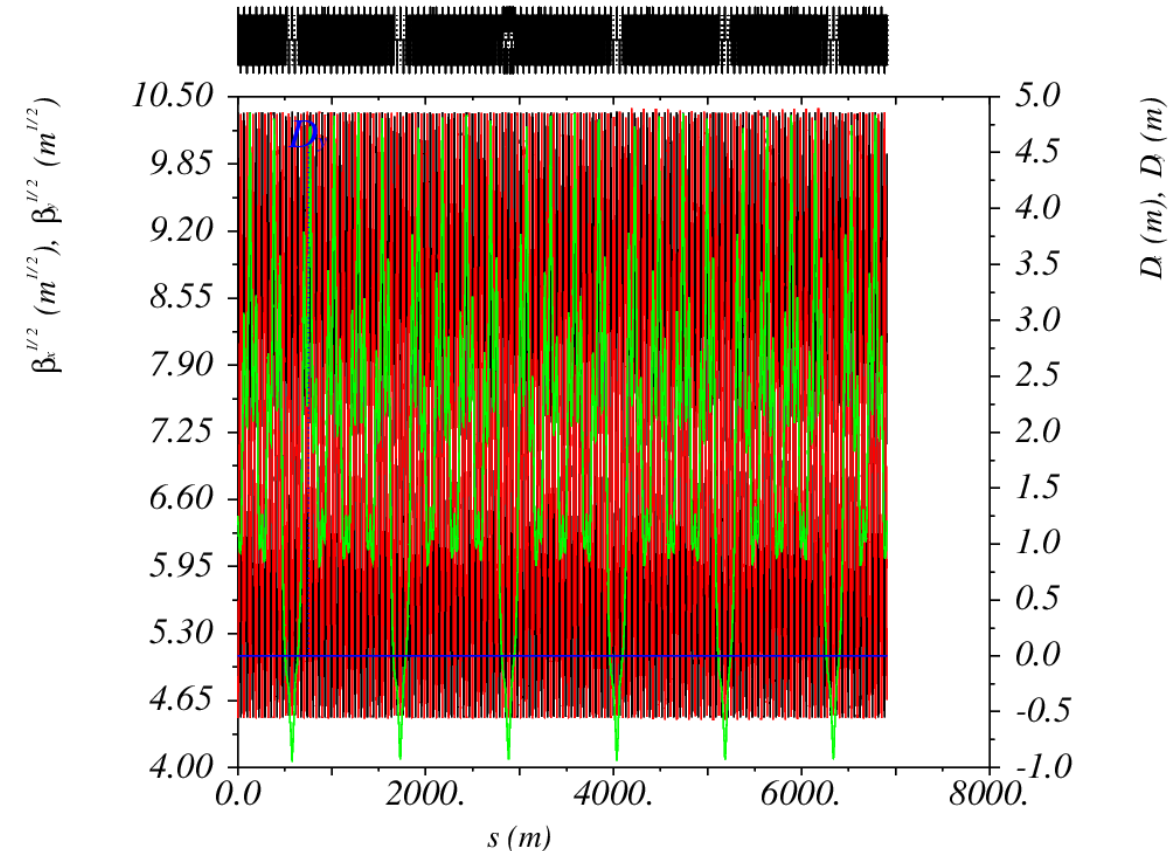

©V. Morozov, Crab Cavity FOA Meeting, Dec 19, 2019

# Hadron Ring Longitudinal Impedance Study

- Estimation of longitudinal impedance threshold for EIC following LHC/FCC-hh coupled bunch instability
- Assumptions:
  - For bunches evenly distributed in the ring
  - Binomial particle distribution  $F_\mu(J) = \frac{1}{2\pi S_\mu} \left(1 - \frac{J}{J_{max}}\right)^\mu$
  - Sing RF system
- Shunt impedance threshold for coupled bunch instability

$$R_{sh} < \frac{f_0 t_{gap} \varphi_{max} V_{rf} \cos \phi_s \Delta f_{s,max}}{2I_b} \frac{\Delta f_{s,max}}{f_{s0}} G(f_r \tau_b) \quad \Delta f_{s,max} = \frac{f_{s0}}{16} \left(1 + \frac{5}{3} \tan^2 \phi_s\right) \varphi_{max}^2$$

Distribution Function:

$$G_\mu(x) = \frac{x}{\mu(\mu + 1)} \min_{y \in [0,1]} [(1 - y^2)^{\mu-1} J_1^2(\pi xy)]^{-1}$$

$J$  – action-angle for Hamiltonian  
 $S_\mu$  – normalization factor  
 $\varphi_{max}$  – maximum long. particle offset  
 in phase

# Hadron Ring Longitudinal Impedance Study

- For only HOMs:
  - With smaller mode bandwidth compared bunch spacing frequency
  - No beam resonances on the modes
- $\mu=2$  is the general choice
- Estimates for maximum energy operation with  $\phi_{\max} = 6\sigma$ , not for beam ramp ups

	Unit	Peak E	Peak Lumi
Revolution frequency $f_0$	kHz	78	78
Bunch spacing $t_{gap}$	ns	35.5	8.9
Maximum longitudinal phase to 591 MHz cavity $\phi_{\max}$		2.97	2.97
Compressor cavity @ 591 MHz voltage $V_{rf}$	MV	28	16.1
Single bunch Current	A	0.00255	0.00086
Crab Cavity fundamental frequency $f_{rf}$	MHz	197	197
Full bunch length $\tau_b$	ns	2.4	2.4

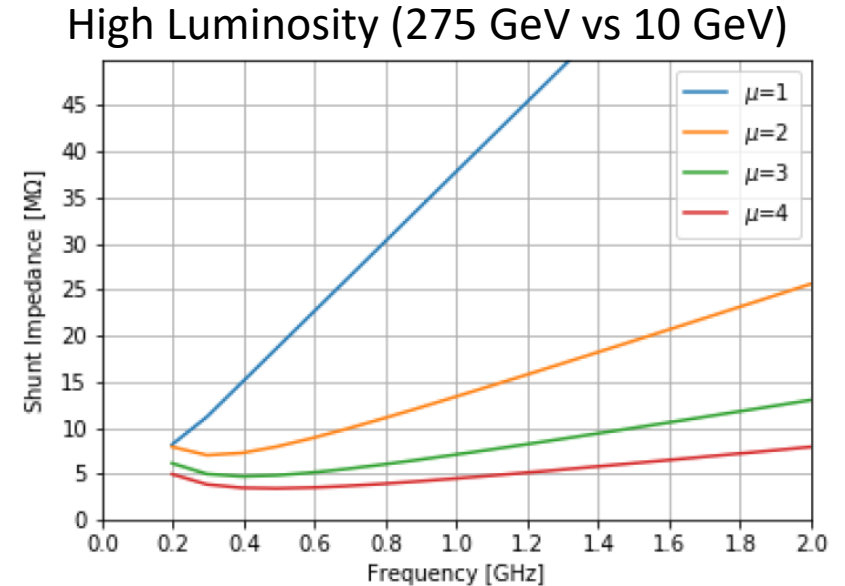
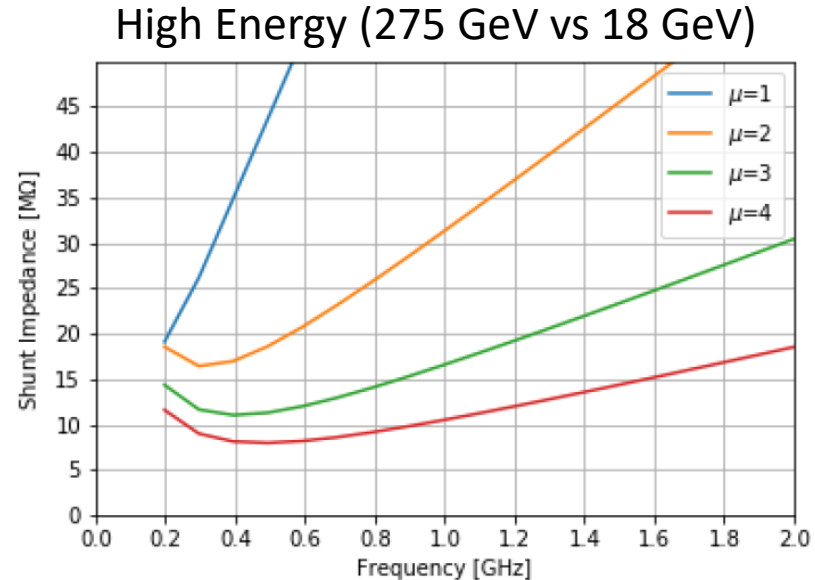
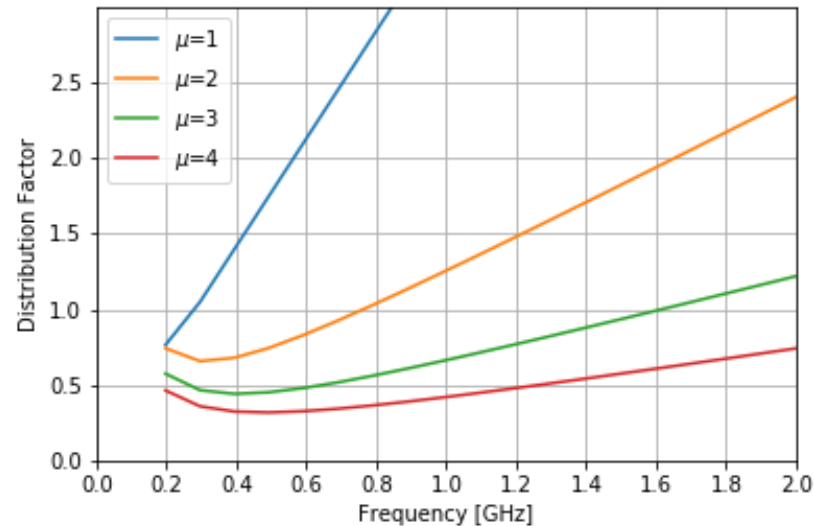



# DQW Stretched Wire Measurement at BNL

- To determine electrical center of the DQW crab cavity
- Due to asymmetry in the crab cavity geometries, the electrical center is not same as the cavity mechanical center
- Calibration allows the electrical center to be aligned with the beam trajectory during operation
- Wire stretching measurement system adapted from the JLAB system

Stretched Wire System



Ref: H. Wang, Wire Stretching Technique for Measuring RF Crabbing/Deflecting Cavity Electrical Center and a Demonstration Experiment on Its Accuracy, Proceedings of NAPAC2016, Chicago, IL, USA, p 225-229

# DQW Stretched Wire Measurement at BNL

Transverse electrical field in DQW cavity

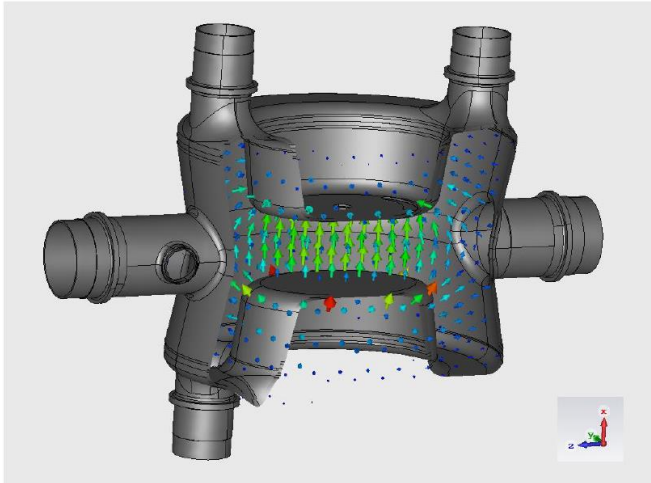

- NA signal scan from the stretched wire at different locations
  - On electrical center plane (yellow)
  - Off electrical center plane (orange)
- Electrical center plane is along the symmetry plane of the deflecting plates with small rotating angles
  - Rotation angle along X axis:  $-0.0017$  deg
  - Rotation angle along Y axis:  $-0.3143$  deg
  - Rotation angle along Z axis:  $0.3067$  deg

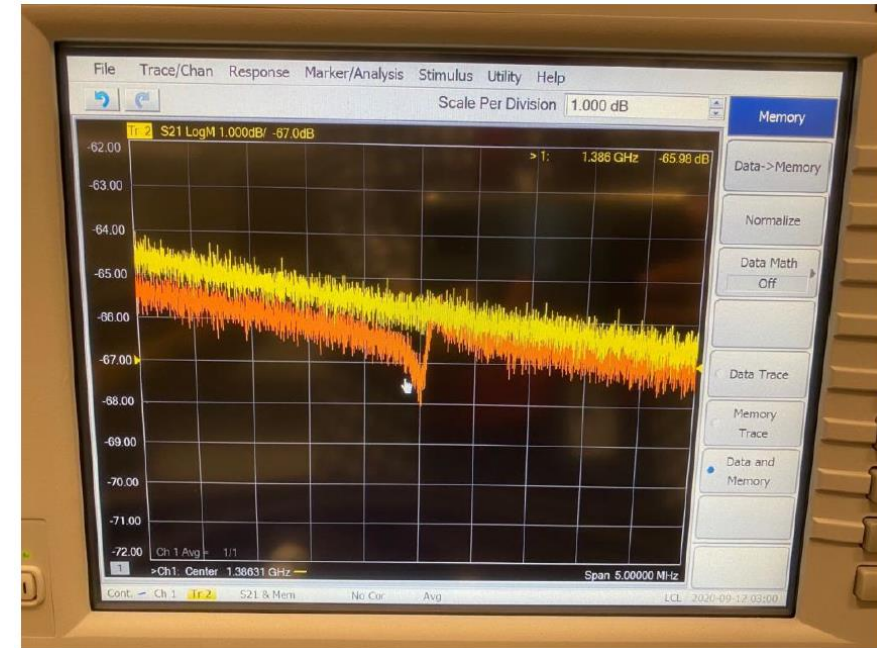

# Workshop: Tutorials on Impedance and Instabilities

- Goal:
  - Learn CERN codes PyHEADTAIL, DELPHI in calculating beam instabilities for crab cavities in EIC
  - Educate young accelerator scientists
- Hosted by ODU
- Instructors:
  - Benoit Salvant (CERN)
  - Carlo Zannini (CERN)
- Workshop scheduled for – June 4-12, 2020
  - June 4 – Visit to JLAB and guest lectures
  - June 5 – Measurement and sim. computers set up
  - June 8-12 – Workshop days
- Participants 20 max from BNL, JLAB and ODU

- Postponed due to Covid-19
- Will reschedule when travel can resume

Finalized Schedule

Time	Mon, Jun 8	Tue, Jun 9	Wed, Jun 10	Thu, Jun 11	Fri, Jun 12
8.30 am – 8.45 am	Registration				
8.45 am – 9.00 am	Welcome				
9.00 am – 10.00 am	Concept of impedance. Why do we care?	Instabilities and introduction to PyHEADTAIL	Building and maintaining impedance models	Instability mitigation	Full example #2 (1/4)
10.00 am – 10.30 am	Break				
10.30 am – 12.00 pm	Using CST for impedance simulations	PyHEADTAIL tutorial	Full example #1 (1/3)	Full example #1 (3/3)	Full example #2 (2/4)
12.00 pm – 1.30 pm	Lunch				
1.30 pm – 2.30 pm	Theory of impedance measurements	Instabilities (mode approach)	Impedance mitigation	Summary	Full example #2 (3/4)
2.30 pm – 3.00 pm	Break				
3.00 pm – 4.30 pm	Measurement tests	Tutorial on Vlasov solvers	Full example #1 (2/3)	Questions/Outing	Full example #2 (4/4)
	Lectures	Measurements	Simulations	Outing	

# EIC Crab Cavities

Ion beam parameters:

Parameter	LHC	EIC – High Energy	EIC – High Luminosity	Units
Energy	7000	275	275	GeV
Ave. Current	1.09	0.74	1.0	A
rms Bunch Length	7	9.9	6	cm
Frequency	400	591		MHz
<b>Crabbing parameters:</b>				
Frequency	400	197	197	MHz
Beam aperture	84	100		mm
$\beta$ function @ IP	0.15	0.9		m
$\beta$ function @ crab	2616	1300		m
Crossing angle	0.59	25		mrad
Total $V_t$	10	34		MV
$E_p$	< 40	< 45		MV/m
$B_p$	< 70	< 80		mT
<b>Fundamental Power Coupler:</b>				
$Q_{ext}$	$5 \times 10^5$	$3 \times 10^6$		
Power	50	60		kW
<b>HOM Impedance Thresholds per Cavity:</b>				
Long. Impedance	$0.2 \times 10^6$	$3.75 \times 10^3$		$\Omega$
Trans. Impedance	$1.0 \times 10^6$	$1.35 \times 10^6$		$\Omega/m$

Double Quarter Wave (DQW)

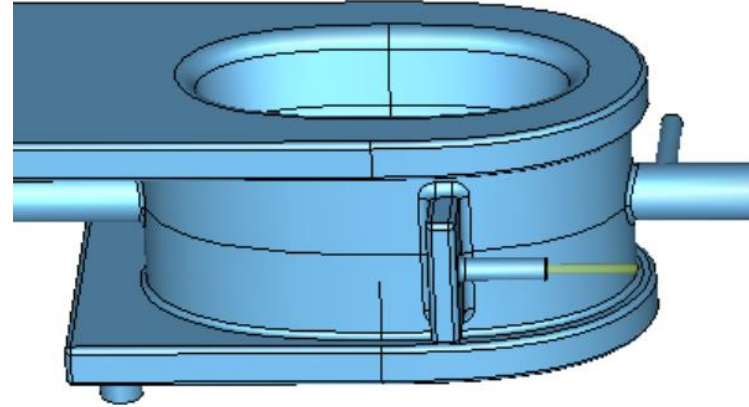

RF Dipole (RFD)

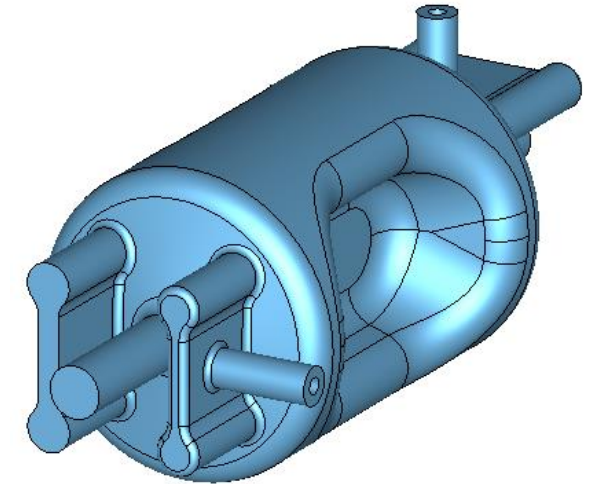

- Both DQW and RFD for EIC are influenced by the LHC crab cavity designs
- Impedance requirements for EIC are tighter compared to LHC

# Challenges of Beam Dynamics in Crab Crossing

- High order modes of crab cavity and its impact to the Dynamic Aperture
- Higher order multipole components and its impact to the Dynamic Aperture
- Noise in amplitude and phase of low-level RF control
- Nonlinearity between crab cavity pairs
  - Beam-beam effect and high order poles of IR magnets
  - Finite bunch length effect
- Optics error of the crab crossing
  - Non-zero dispersion in the location of crab crossing
  - Non-ideal phase advance between crab cavity pairs
  - Local transverse coupling between crab cavity pairs

# Things to Learn from next SPS Tests

- Benchmark codes against SPS data
  - Elegant models for EIC
- Emittance growth rate
  - Tolerances on crab cavity synchronization and their phase and amplitude noise
- Full transverse voltage operation
  - Transparency to beam with crabbing and un-crabbing at operational  $V_t$  of 3.4 MV
  - HOM excitation and HOM coupler operation
- Feedback performance
  - Effect of amplitude and phase noise
- Beam alignment to cavity electrical center and alignment tolerances for the hadron beam
- Crab cavity operation with bunch length scanning
- And more.....

- Reports
  - Visual inspection of NWV-DQW-002 cavity upon reception at BNL from JLAB on Feb, 25, 2020
  - HR Longitudinal Impedance Budget
  - Double Quarter Wave Crab Cavity wire stretching measurement at BNL
  - Study of Crab Cavity Dynamics at CERN and how it is applicable to EIC
- Workshops
  - EIC Accelerator Collaborator Workshop 2020
    - Q. Wu, Status of R&D for EIC
    - S. Verdu-Andres, EIC RHIC Upgrades

# Plans for Next Year

- Travel will again be limited due to Covid-19
- Crab cavity SPS & LHC series – Cancelled due to Covid-19
  - Trim tuning strategy in production
  - HOM coupler surface treatment procedures
- Impedance workshop postponed
  
- Analysis of test results
- Benchmarking EIC simulations with SPS data
- Analytical calculation on crab cavity impedance
- Computer simulation on crab cavity impedance
- Experience of cavity production and assembly over far away sites
- Planning for machine development for DQW Test II in SPS
- Prepare for next series of tests of the RFD cryomodule in SPS
- Collaboration between multiple groups



# Summary

- Although we were not able to participate in onsite activities at CERN in 2020, we were able to achieve significant understanding of the crabbing concept from the lessons learned during previous tests
- Early this year the EIC site decision was made, and we were able to immediately apply the knowledge acquired to the BNL-specific EIC design
- Collaboration between the US crab cavity team and CERN has been beneficial to both
- Work carried out under FOA project has been greatly beneficial to EIC
  - Further participation in the activities at CERN will contribute to the success of EIC
- FOA participants are now EIC contributors:
  - BNL – Qiong Wu, Silvia Verdu-Andres
  - JLAB – Geoffrey Krafft, HyeKyoung Park, Vasiliy Morozov
  - ODU – Jean Delayen, Subashini De Silva

BACK UP

# Master Plan CERN-WP4, Sep 2020

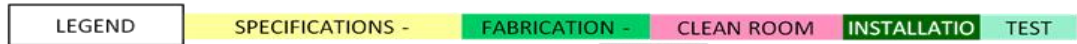
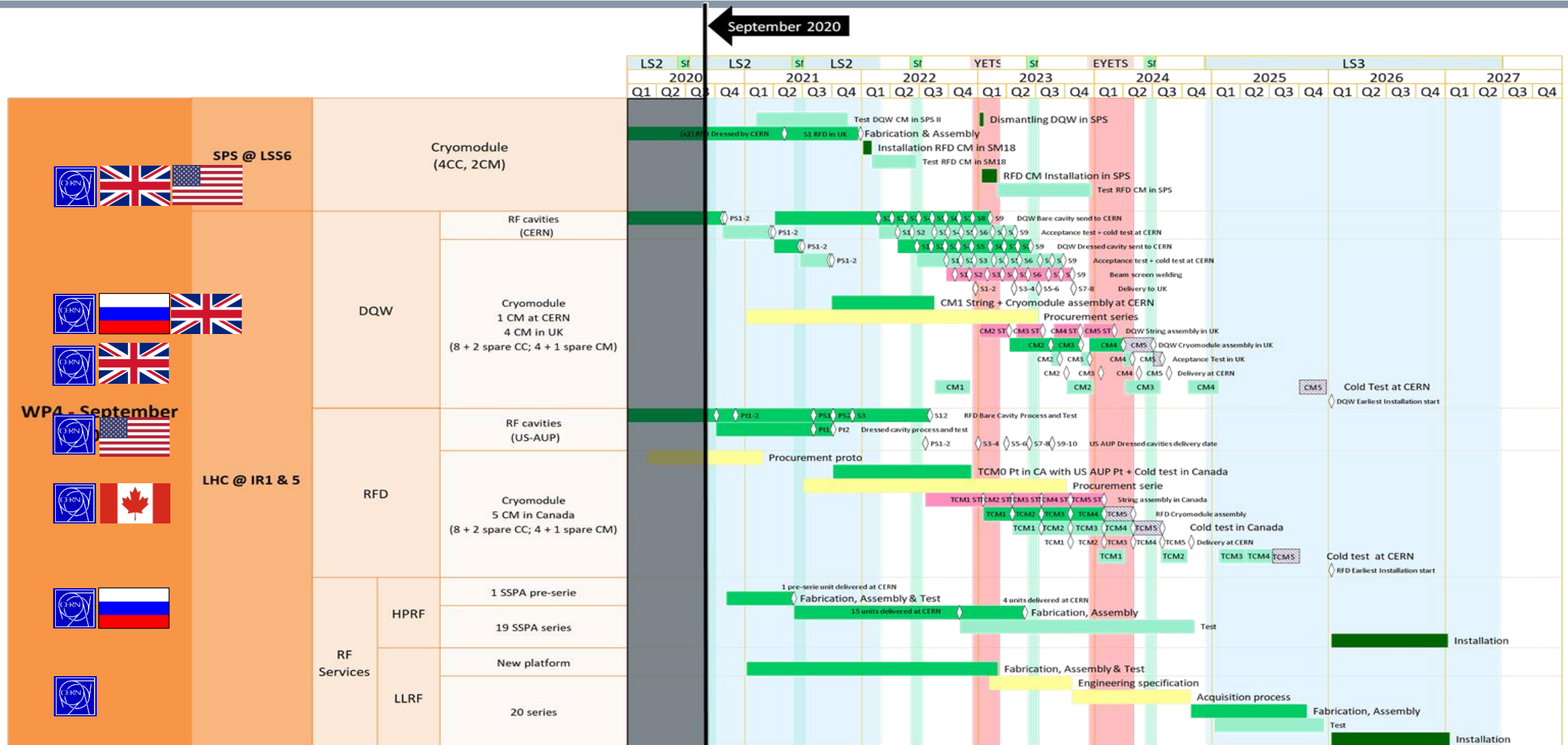

# Benchmarking of Codes – Crab Cavity Transparency

- Both cavities were running at 1 MV/cavity
- Individual cavity phases adjusted to add up or cancel the crab kicks

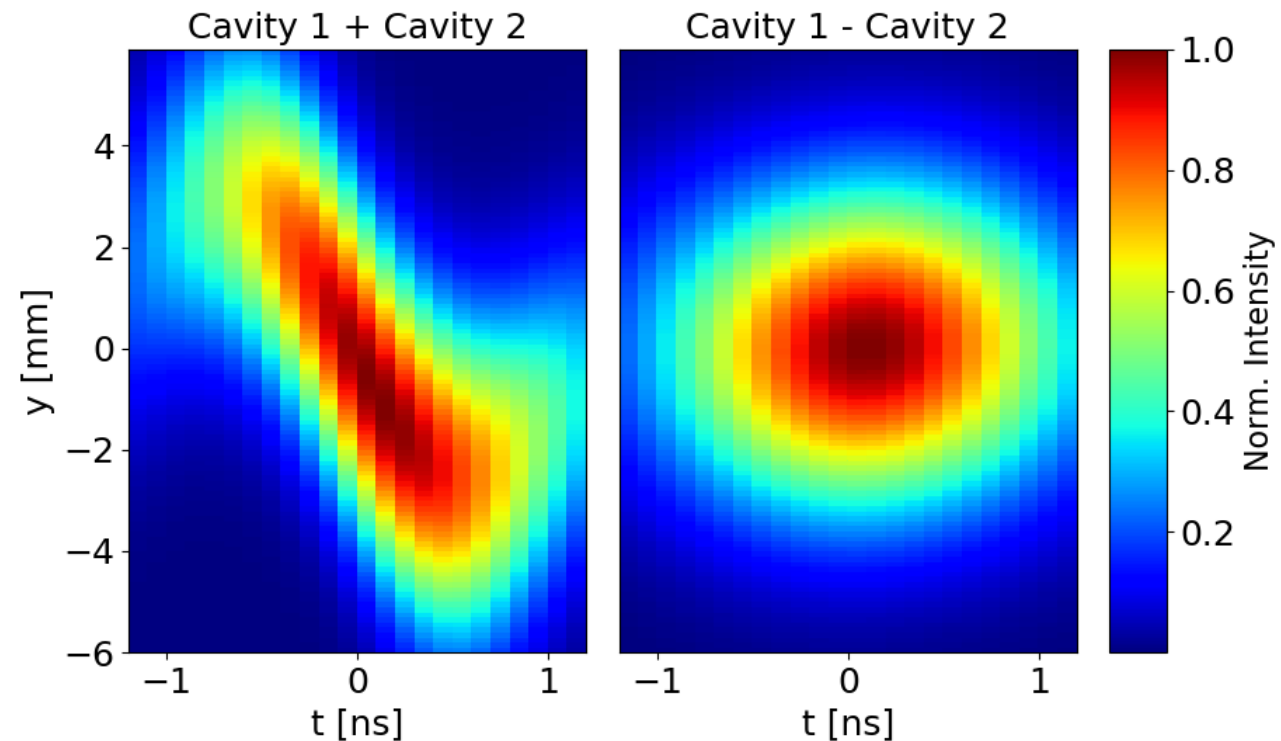
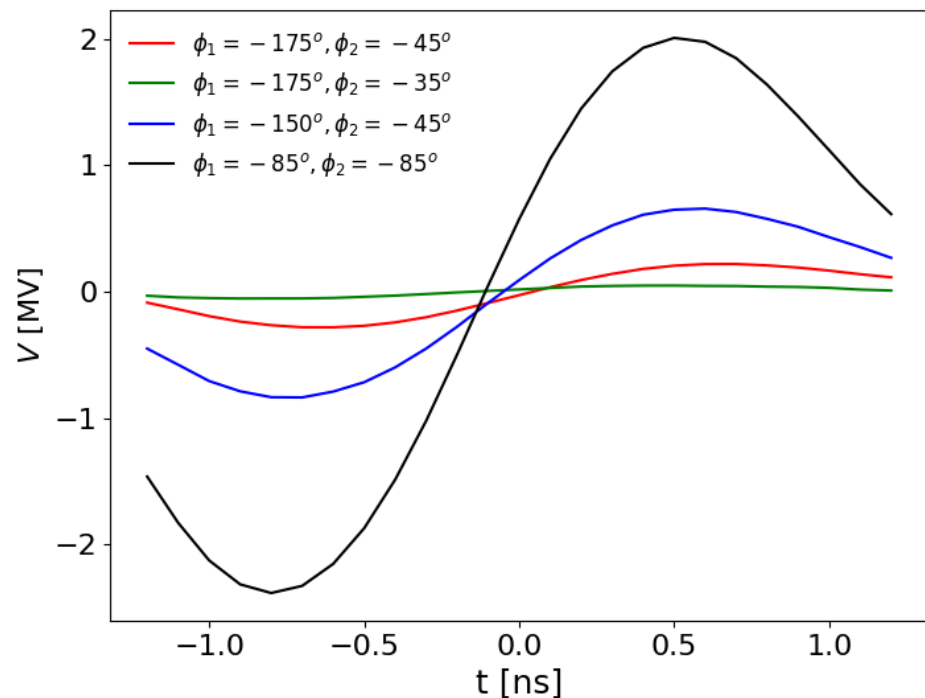

# Benchmarking of Codes – Crab Cavity Phase Variation

- Head-tail monitor measures intra bunch offset
- It was calibrated in terms of CC voltage using BPMs
- Cavity 2 was running at  $\sim 1$  MV while its phase was varied

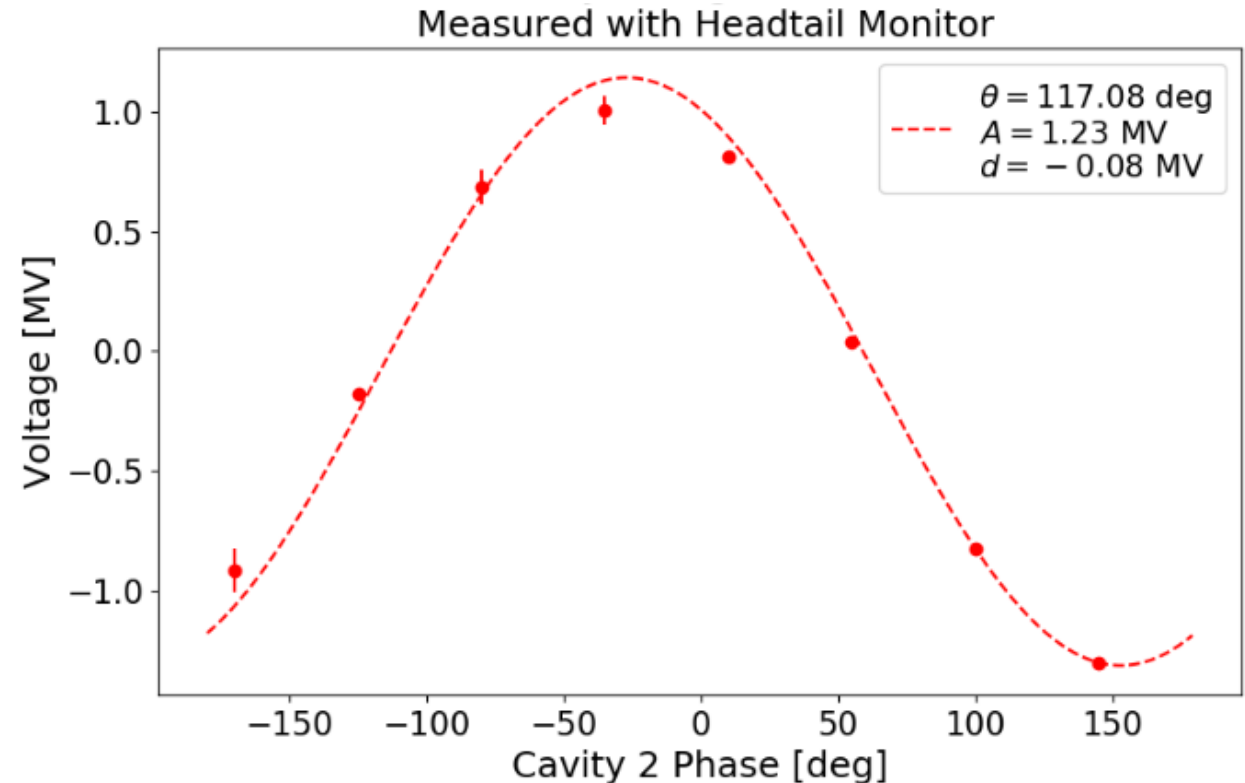
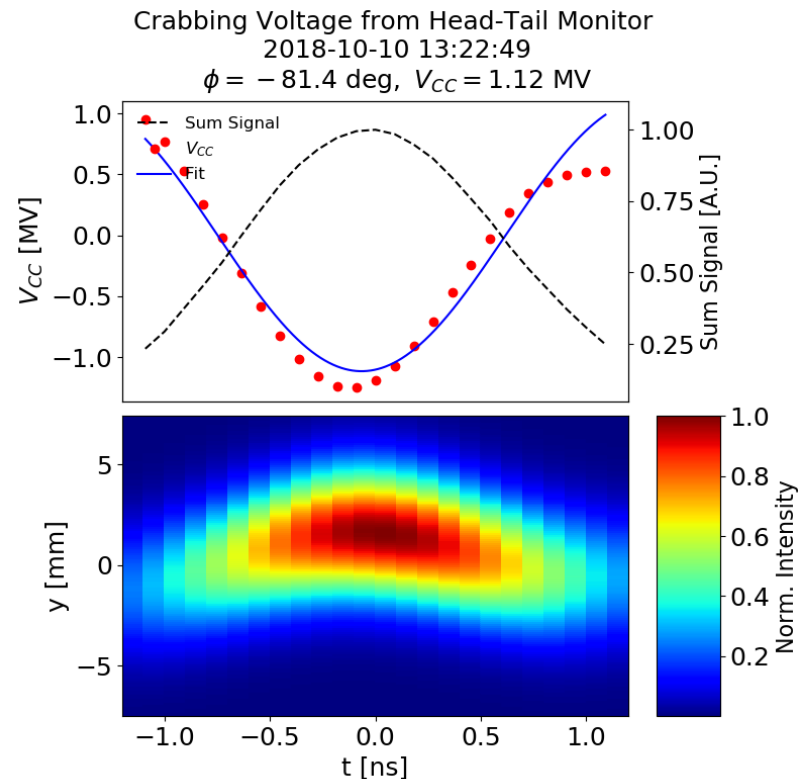

# Production of SPS-RFD Cavities at CERN

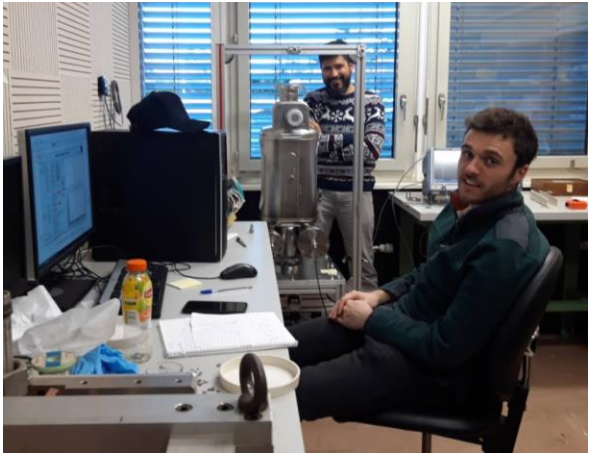
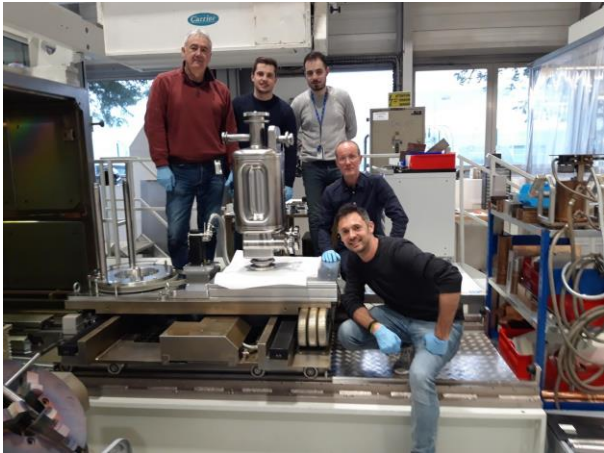

©R. Calaga, 10<sup>th</sup> HL-LHC Collaboration Meeting, CERN, Oct 5-7, 2020

# Cryomodule Progress (UK-STFC/CERN)

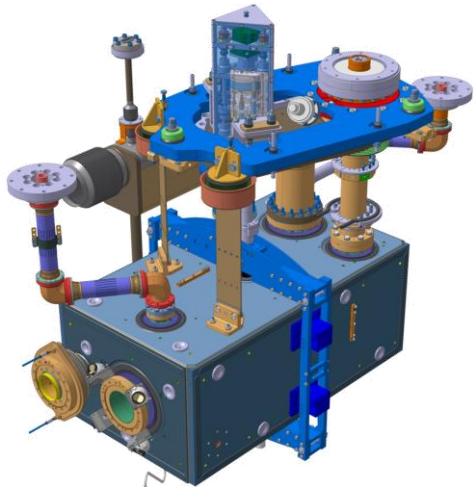

Tuning System



String assembly trolley

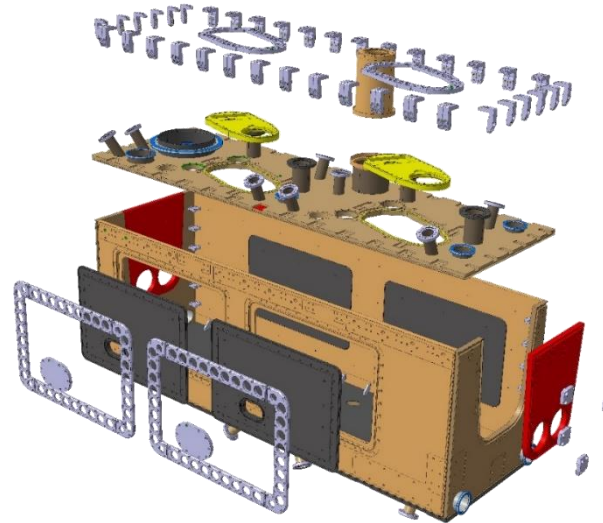

Vacuum vessel

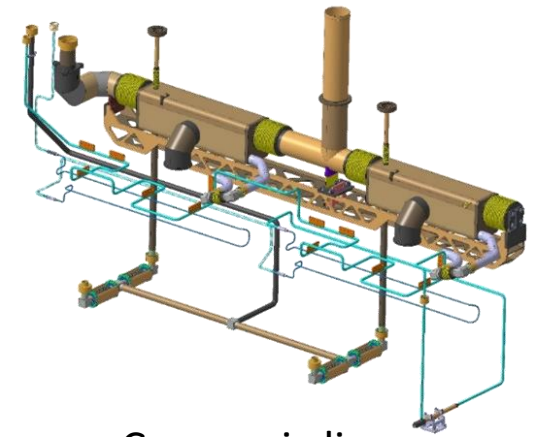

Cryogenic lines & instrumentation

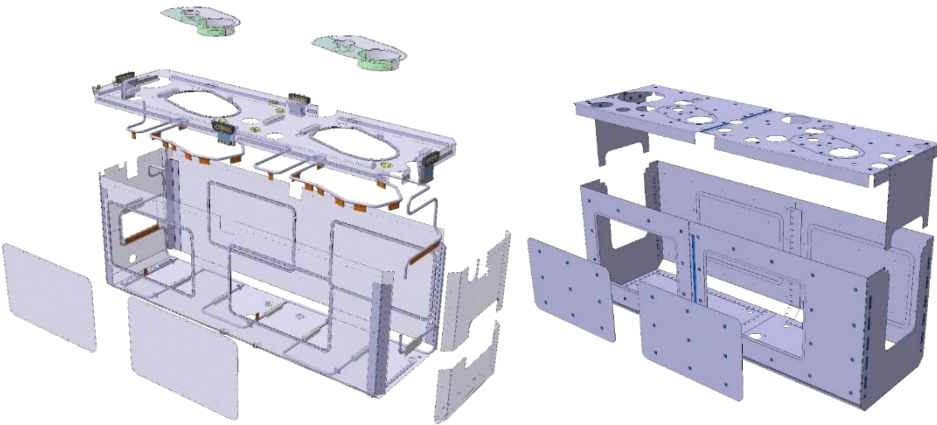

Thermal/magnetic shield

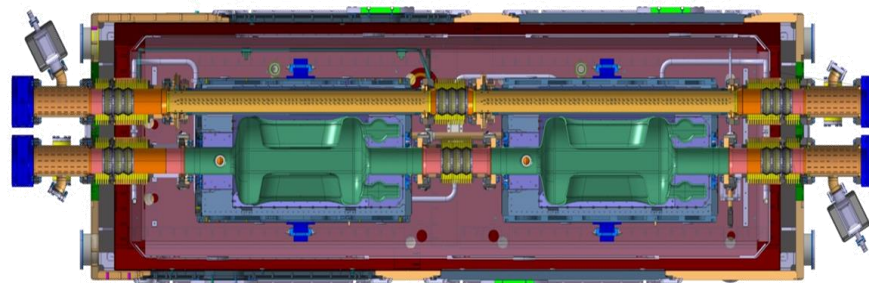

Beam lines & vacuum layout

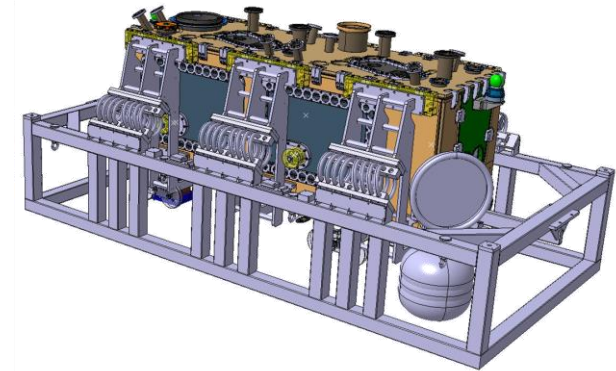

Transport Studies/Frame

HL-LHC WP4, Annual Meeting 2020